



SIGNAL BELL

Applications

Audible signalling unit
for:

- Machinery Alarms
- General Alarms
- Fire Alarms
- Call Systems
- Annunciators
- Paging

Features

- Rated 98 dBA at 10 ft. (3 meters)
- Low Power requirement
- Can be used outdoors with optional weather-proof enclosure
- Extended contact life on DC units with optional transistorized drivers.

TYPE 8540-1316

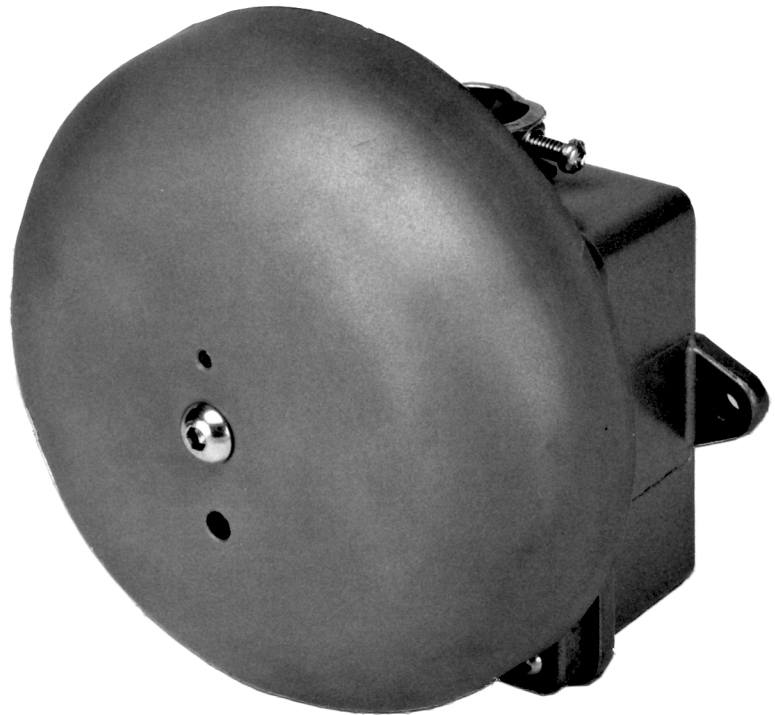

PRIME MOVER CONTROLS INC.

VANCOUVER, BC, CANADA

DESIGN, MANUFACTURE AND SERVICE OF MARINE AND
INDUSTRIAL CONTROL COMPONENTS AND SYSTEMS

Electronic - Pneumatic - Hydraulic - Mechanical

SB-8540-1316



Prime Mover Controls Inc.
Vancouver, BC, Canada

DATE 87NOV10
DWN R.P.D.
SCALE NONE

SIGNAL BELL

DWG No. A-8540-1316 REV 2

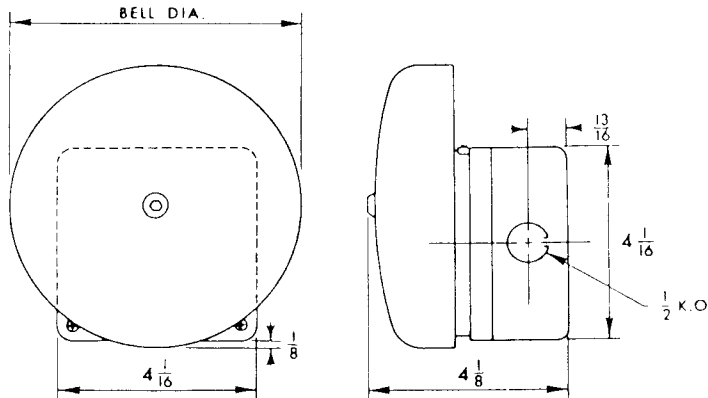

GENERAL PURPOSE BELL

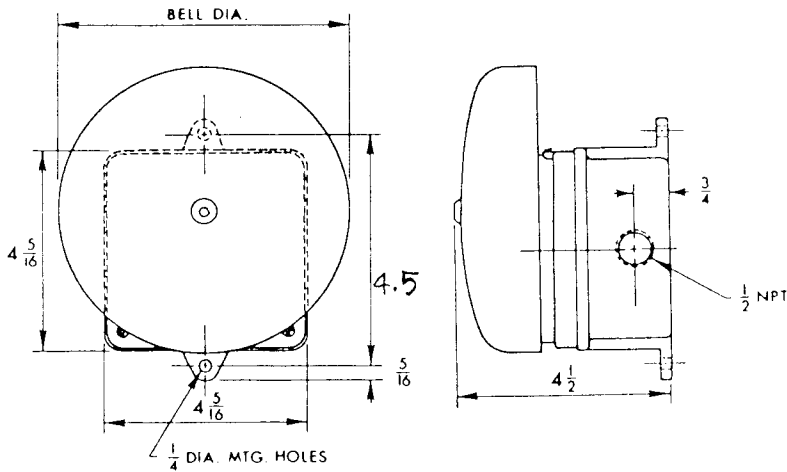

WEATHERPROOF BELL

PART NUMBER SELECTION GUIDE

PART No. **8 5 4 0** - **1 3 1 6** - [] [] [] []

MCP PRODUCT
AUDIBLE UNIT

BELL SIZE	
4 INCH DIA.	4
6 INCH DIA.	6
10 INCH DIA.	A

HOUSING	
GEN. PURPOSE	G
WATERPROOF	W

	4"	6"	10"
dBA AT 10'(3M)	98	100	102
WEIGHT - GP OR WP	1.02kg 2.25lbs	1.36kg 3.00lbs	2.61kg 5.75lbs

NOTE: OPTIONAL TRANSISTORIZED DRIVER (USED TO EXTEND CONTACT LIFE) IS ONLY AVAILABLE ON DC UNITS.

OPERATION	
S	STANDARD
T	TRANSISTORIZED

POWER	
1	12VDC .8AMPS
2	24VDC .4AMPS
3	32VDC .4AMPS
4	125VDC .08A
5	115VAC .08A

THIS DRAWING SHALL NOT BE REPRODUCED OR USED FOR MANUFACTURE, PRODUCTION, OR PROCUREMENT WITHOUT THE EXPRESS WRITTEN PERMISSION OF PRIME MOVER CONTROLS INC.