

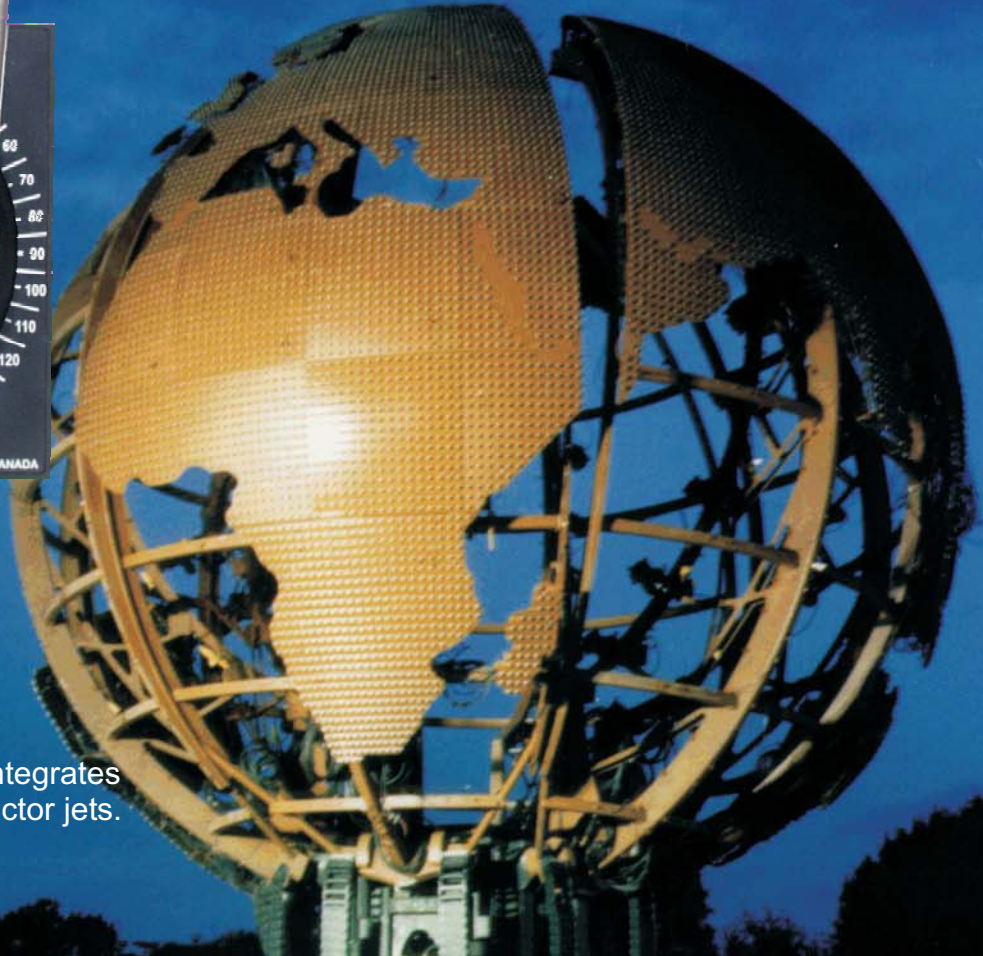

PMC Z-MaC GOES TO DISNEY WORLD

- TYPE 5360 AZIMUTH CONTROL HEAD
- TYPE 8161 AZIMUTH DISPLAY METER
- TYPE 3380-1100 SPEED ACTUATOR
- TYPE 3380-1300 GEAR ACTUATOR
- TYPE 2302 POSITION TRANSMITTER



The Earth Globe self propelled barge has a PMC Z-MaC Control System. This comprehensive system integrates engine, reversing gear and tractor jets.



PRIME MOVER CONTROLS INC.

SIMPLIFIED BLOCK DIAGRAM

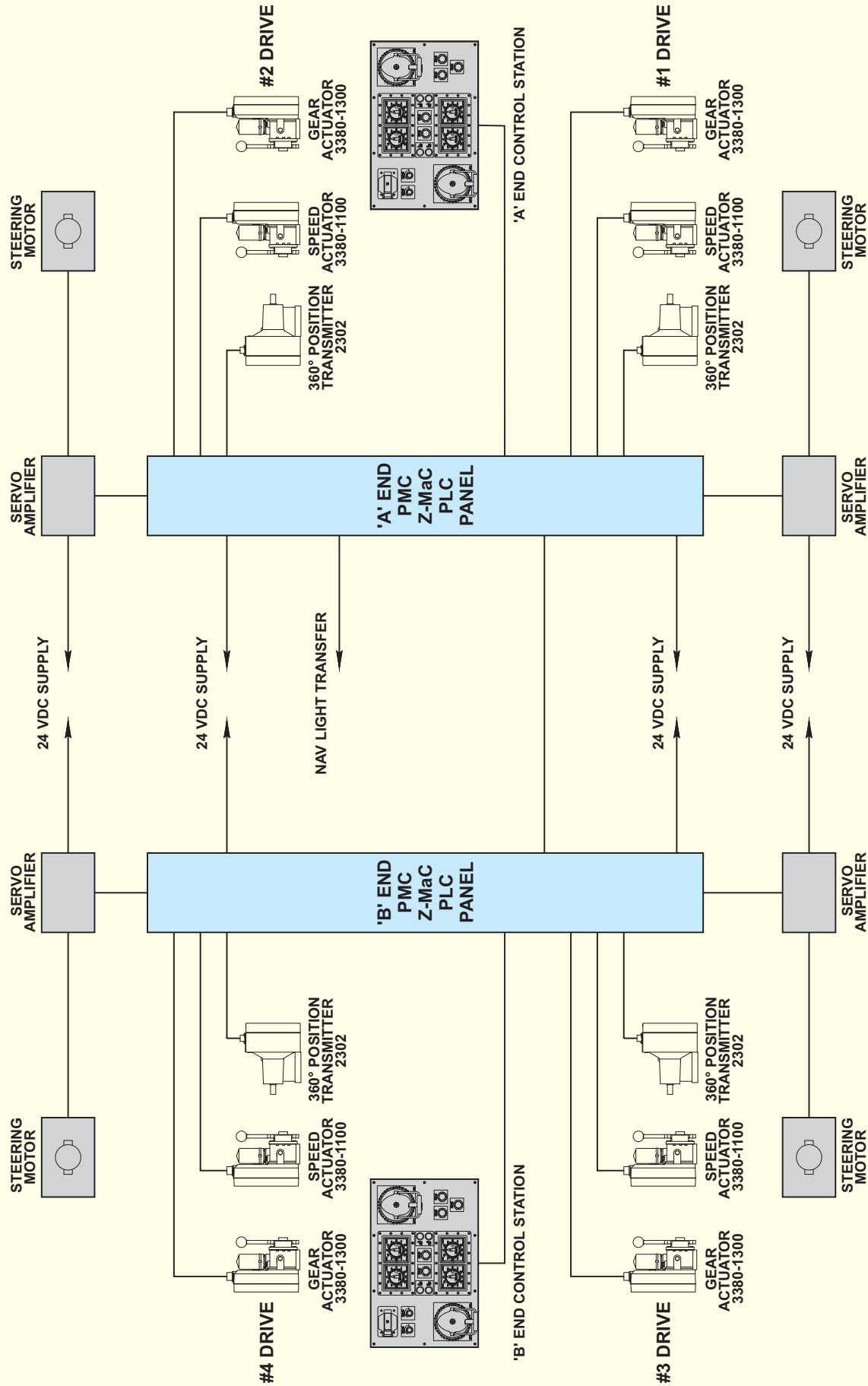

PRIME MOVER CONTROLS INC.

3600 GILMORE WAY, BURNABY B.C. CANADA V5G 4R8

TEL (604) 433-4644 FAX (604) 433-5570 www.pmc-controls.com